

Data sheet

Oil Pump Type RSH Size 32, 63, 95, 125

Application

RSH oil pumps are designed for small/medium sized domestic and commercial oil burners up to 285 l/h.

The pumps have a built-in pressure regulator with shut-off function.

A special regulation spring is available for feed/transfer applications.

Features

- Light and heavy oil
- 1 or 2-pipe operation
- 1-stage
- Built-in pressure regulator with shut-off
- Ring filter
- Special spring available for feed/transfer applications

Function

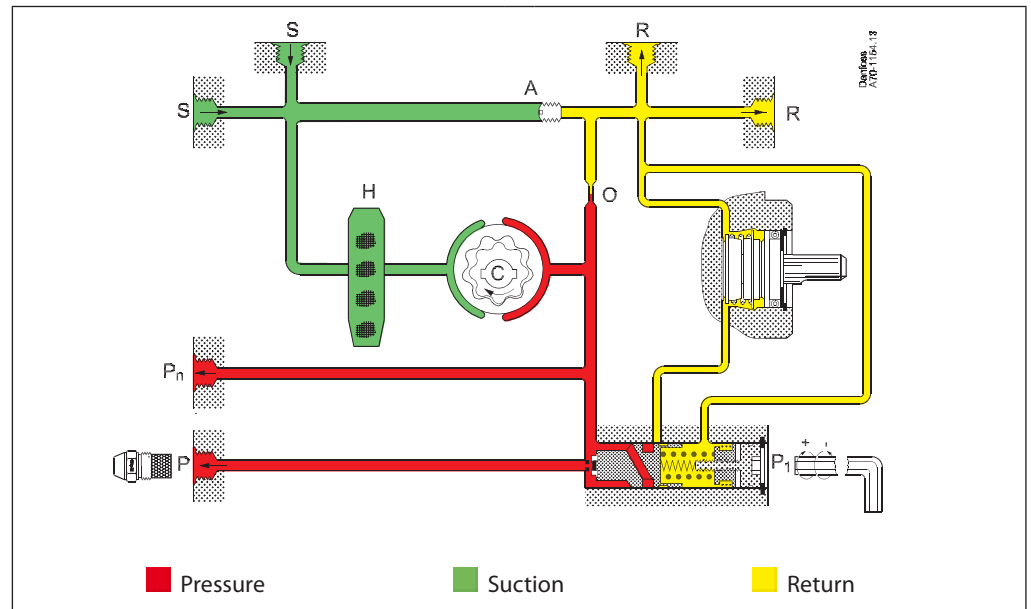

From the suction inlet (S) oil is drawn through the gear set, where the pressure is increased. By means of the piston and the spring in the pressure regulator the pressure is kept constant at the value set on adjustment screw (P1).

In 2-pipe systems the excess oil is led back to the return outlet (R). In 1-pipe systems with plugged return outlet (R) and removed by-pass screw (A), the oil is returned internally to the gear set (see figure).

When the pump is stopped the pressure drops and the spring force in the pressure regulator will move the piston until it seats and the oil flow is shut off effectively.

Bleeding

In 2-pipe systems the pumps are self-priming, i.e. bleeding is performed via the constriction (O) to the return outlet (R).

In 1-pipe systems with plugged return outlet (R) and by-pass screw (A) removed, bleeding must be performed through the pressure gauge port (Pn). In 1-pipe systems with underlying tank, the closing function of the regulating valve must be rendered inoperative. This is made by connecting the nozzle line to the pressure gauge port (Pn) and plug the pressure port (P). In this application a cut-off valve must be installed in the nozzle line.

Warranty

For pumps used outside the stated technical data and used with oil containing abrasive particles Danfoss cannot give any warranty.

Identification

Example:

RSH 63

- 32 = Capacity 91 l/h
- 63 = Capacity 143 l/h
- 95 = Capacity 210 l/h
- 125 = Capacity 285 l/h

Nozzle capacity at 20 cSt., 15 bar, 2800 min⁻¹.

Technical data

RSH	32	63	95	125
Oil types	Standard fuel gas oil, heavy oil and bio fuels			
Viscosity range (measured in suction inlet)	4.3 - 200 cSt. (mm ² /s)			
Filter area / mesh	75 cm ² / 340 μm		170 cm ² / 340 μm	
Pressure range, stage	15-35 bar			
Factory setting	21 ±1 bar			
Max. pressure in suction inlet/return outlet	4 bar			
Speed	1400-3450 min ⁻¹			
Max. starting torque	0.22 Nm	0.25 Nm	0.30 Nm	0.35 Nm
Ambient temperature	-20 to +120 °C			
Storage temperature	-25 to +120 °C			
Temperature of medium	-10 to +120 °C			
Neck / Flange	EN 225			

Nozzle capacity

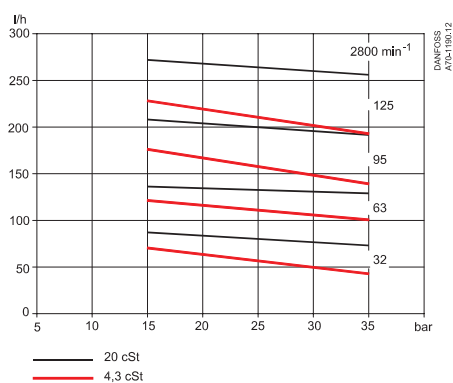

Operating torque

Power consumption

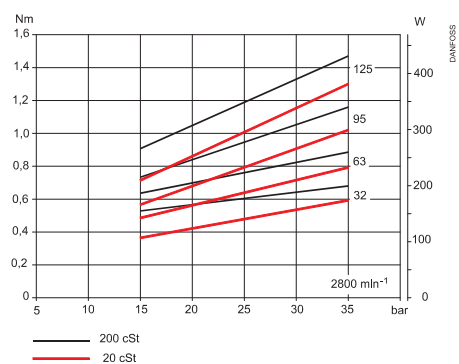

Connections

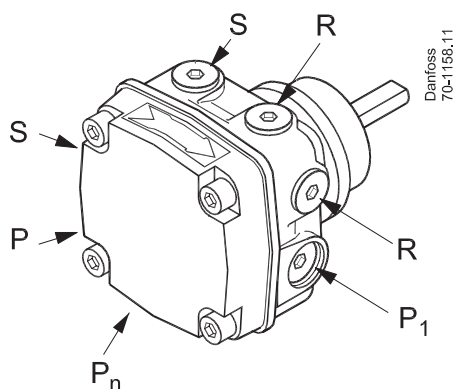

- P₁:** Pressure adjustment
- S:** Suction inlet G1/4
- R:** Return outlet G1/4
- P:** Pressure outlet G1/4
- P_n:** Pressure gauge port G 1/8
- H:** Filter

Change-over and Filter Replacement

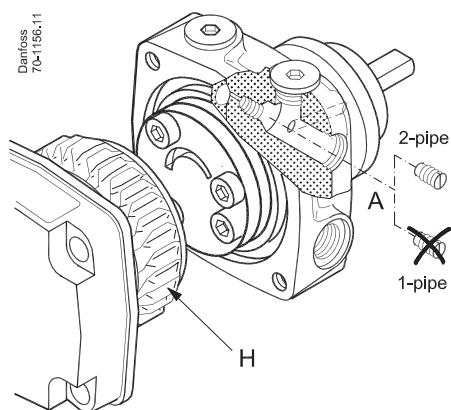

- H:** Filter
- A:** 2-pipe operation, with screw
- B:** 1-pipe operation, without screw

Dimensions

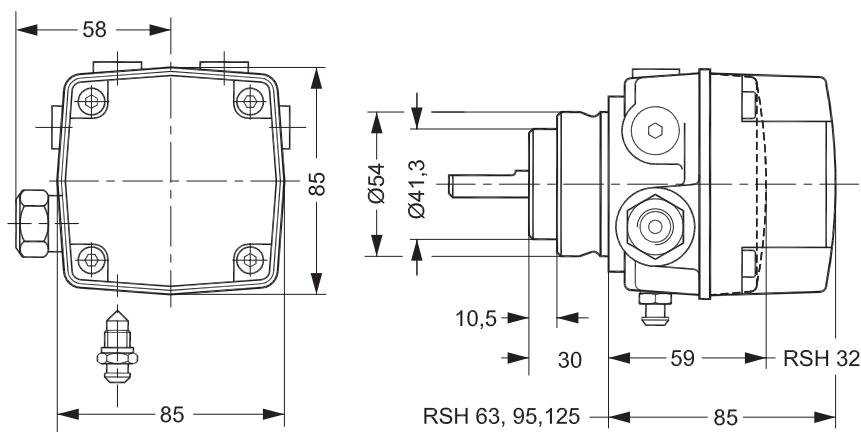

TYPE	L	L
RSH 32	28,8	60,8
RSH 63	26,8	58,8
RSH 95	-	62,0
RSH 125	-	62,0

Danfoss
70-1183.13



Additional documentation on burner components is available on <http://heating.danfoss.com/>

Danfoss A/S

Heating Segment • heating.danfoss.com • +45 7488 2222 • E-Mail: heating@danfoss.com

Danfoss can accept no responsibility for possible errors in catalogues, brochures and other printed material. Danfoss reserves the right to alter its products without notice. This also applies to products already on order provided that such alterations can be made without subsequential changes being necessary in specifications already agreed. All trademarks in this material are property of the respective companies. Danfoss and all Danfoss logotypes are trademarks of Danfoss A/S. All rights reserved.
